

CVap®

HMD018 CVap® Mobile Holding Cabinet

Full size model, fanless

Electronic differential control, single dial



HMD018

General Specifications

- **Winston's CVap® mobile holding cabinet with a single dial control maintains a constant 160°F (71°C) while controlling the food texture from moist to very crisp.**
- Patented Controlled Vapor Technology (U.S. patent #5,494,690) establishes that the water vapor content in the cabinet is the same as that of the food. This process controls moisture evaporation and saturation, so crisp foods stay crisp, moist foods stay moist.
- Built to last with quality craftsmanship, high grade stainless steel construction and full insulation on top, sides, and doors.
- Rugged, high-mobility Jarvis E-Z Rider 5" (127mm) casters roll quietly and smoothly, with increased maneuverability and reduced vibration. Rolls easily over a variety of surfaces.
- Recessed handles on sides and extended handle on back facilitate push and pull mobility by one person.
- Perimeter bumpers prevent damage to cabinet sidewalls.
- Features full perimeter door gaskets, magnetic door handles, lift-off doors, removable rack supports, and digital readout for water temperature.
- CVap equipment complies with all domestic, and most international requirements, such as UL, C-UL, UL Sanitation, CE, MEA, and others.
- This model has earned the ENERGY STAR®.

Functions: Holding
Transport

Capacity: 10 Sheet Pans
18" x 26" x 1.25"
457mm x 660mm x 32mm)
20 Steam Table Pans
12" x 20" x 2.5"
(305mm x 508 x 64mm)
10 x 2/1 Gastronorm Pans

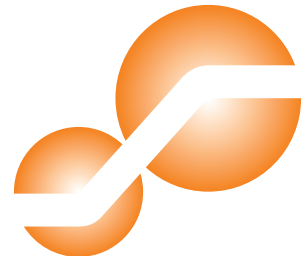

Winston Industries, LLC.



Winston Products International, Ltd.



HMD018 CVap® Mobile Holding Cabinet

Full size model, fanless

Electronic differential control, single dial

Buy Winston Service Parts Online!
Factory direct at
www.winstonind.com

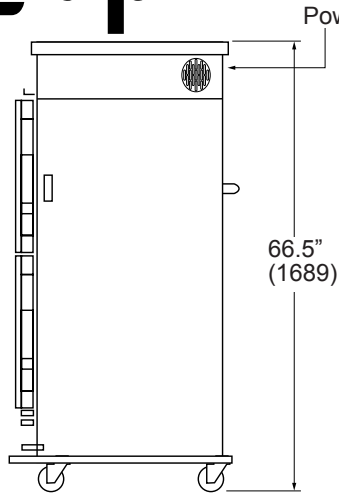

Side

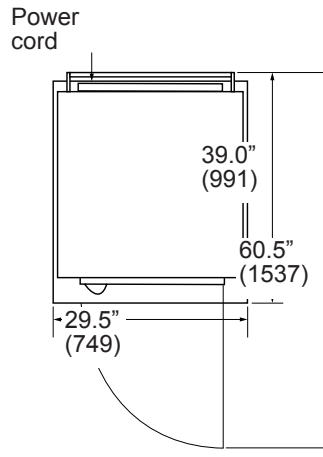

Plan

Drawings not to scale

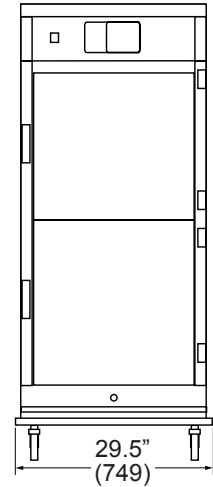

Front

Capacity	Size in (mm)	Volts	Hertz	PH	Amps	Watts	Circuit Amps	Ship Wt lb (kg)	Ship Cube ft (M)	Class	NEMA Plug Type
10 SP	H= 66.5" (1689) W= 29.5" (749) D= 39.0" (991)	US/Canada									
20 STP		120	60	1	15.3	1840	US 15 CAN 20	w/skid 315 (142)	55.5 (1.6)	100	 5-15P United States 5-20P Canada
10x2/1 GP	International										
		230*	50/60	1	8.0	1840	N/A	w/skid 315 (142 kg)	w/skid call factory	N/A	

SP=Sheet Pan (18"x26"x1.25") • STP=Steam Table Pan (12"x20"x2.5") • GP=Gastronorm Pan

Short Form Specs

Shall be Winston CVap mobile holding cabinet, model HMD018 with single dial control to provide precise food temperature at 160°F (71°C) and maintain food texture with settings from moist to very crisp. Utilizes Controlled Vapor technology (patent #5,494,690) as a method and apparatus for holding hot foods, consisting of an air heater and water heater to establish ideal water vapor content that is in relation with the moistness characteristics for the food. Uniflo airflow design provides even heat distribution.

Construction

Materials: To be commercial and institutional grade stainless steel to provide ease of cleaning and long service life with reasonable use and care.

Racks: Adjustable, normally spaced 3.5" (89 mm), to receive 10 sheet pans, 20 steam table pans, or 10 x 2/1 gastronorm pans. Removable for cleaning.

Doors: Field reversible hinges to allow door lift-off to facilitate cleaning. Magnetic door handles.

Casters: Includes 2 locking, 2 non-locking, heavy duty, non-marking Jarvis E-Z Rider 5" (127mm) casters.

Insulation: Full-perimeter.

Controller: Single electronic automatic dial allows precise control of food temperature at 160°F (71°C) and allows food texture to be set automatically with moist to very crisp settings.

Water fill: Operated manually. Low mineral potable water is recommended, otherwise use deionizer/demineralizer to minimize corrosive damage.

Ventilation: Allow 2" (51mm) clearance on sides, particularly around ventilation holes. Install with supplied legs or casters. Refer to use & care manual for specific installation instructions. Generally this appliance doesn't need to be installed under a mechanical ventilation system (vent hood). Check local health and fire codes for requirements specific to your location.

Electrical: Supplied with 84" (2314mm) (minimum) power cord and plug.

Load limit: 65 lbs. (29.25 kg) per rack.

Warranty

Limited 1 year warranty (excluding gaskets, lamps, hoses, power cords, glass panels, and evaporators). Warranty disclaimer for failure to clean. Ask for complete warranty disclosure.

Model

HMD018

Description

CVap hold/transport, mobile, 5" casters

Customer should specify the following when ordering:

1. Hinge preference (left or right) (no additional cost).
2. Any added options or accessories.

* Inquire about additional international voltages available.

Options

Hinging	Specify left hand or right hand hinge
Pass Thru	Second pair of doors on back of cabinet
Windows	Window in upper and lower door
Pass Thru/Windows	Second pair of doors on back of cabinet, windows in all four doors
Solid Rack Supports	Solid stainless steel rack supports (replaces standard wire rack supports)
Water Fill System	Automatic water fill system
Extended Warranty	Adds parts and labor warranty coverage for one additional year

Optional Items

PS2192/12	ScaleKleen™ packets (12 pack)
PS2206/4	Wire rack (4-pack)
PS2359	One additional rack support (2 required)
PS2696	Mobile water removal system

Options and optional items available for an additional cost.

Winston Industries, LLC.



Winston Products International, Ltd.

2345 Carton Drive • Louisville, KY 40299 USA • (800) 234-5286 • (502) 495-5400 • Fax: (502) 495-5458 • www.winstonind.com

Printed in USA.

Specifications subject to change without notice.

4272W145 Rev 23
rs 4-21-09