



CAC507 CVAP® COOK & HOLD OVEN

EXCLUSIVE TECHNOLOGY

Patented Controlled Vapor Technology (U.S. patent #5,494,690) establishes that the water vapor content in the oven is the same as that of the food. This unique process cooks food fast, produces high yield and precise control of internal food temperatures.

EASY-TO-USE CONTROLS

Microprocessor allows simple push-button operation with just three inputs; Doneness Temperature (90 to 200° F (32 to 93° C)), Browning Level (from 0 for high yield, to 10 for optimum browning), and Cook Time. Never needs calibration.

DURABLE

Built to last with quality craftsmanship, high grade stainless steel construction, and full insulation on top, sides, and doors. Features perimeter door gaskets, magnetic door latches, lift-off doors, removable side racks, and digital readout.

BETTER CONTROL OF FOOD QUALITY

When the cook cycle is complete, oven will automatically switch to hold mode. Hold your menu items at just-cooked quality and precise serving temperatures for extended times.

INDUSTRY COMPLIANT

CVap equipment complies with domestic and international requirements such as UL, C-UL, UL Sanitation, CE, MEA, and others.



CAC507
CVAP® COOK & HOLD OVEN
HALF SIZE UNDER COUNTER
MODEL WITH FAN
8000 Series Electronic Controls

CVap® Cook & Hold Ovens are designed to perform a wide variety of applications and techniques, including cooking & staging, poaching, braising, low-temp steaming, bagless sous vide, confit, low-temp baking, and more.





CAC507 CVAP® COOK & HOLD OVEN
HALF SIZE UNDER COUNTER MODEL WITH FAN
 8000 Series Electronic Controls

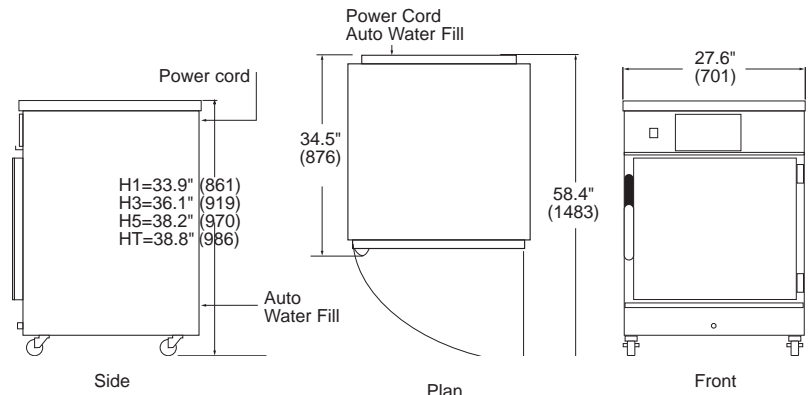

DRAWINGS NOT TO SCALE

capacity	size in (mm)	volts	hertz	ph	amps	watts	nema	ship wt. lb (kg)	ship cube
US / CANADA									
4 Half SP 8 STP	H1= 33.9" (861) H3= 36.1" (919)	208	60	1	24.0	4990	US 6-30P	240 (109)	C1,3=26.6 (0.75) C5=30.1 (0.85)
4 Half STP 8 GP 1/1	H5= 38.2" (970) HT= 38.8" (986) W= 27.6" (701) D= 34.5" (876) DT= 37.6" (955) DP= 36.4" (925)	240	60	1	21.1	4990	CAN 6-30P		
INTERNATIONAL									
		230*	50	1	23.3	5365	N/A	240 (109)	call factory

SP= Sheet Pan (18" x 26" x 1.25") • STP= Steam Table Pan (12" x 20" x 2.5") • GP= Gastronorm Pan
 H1= Height w/1" wheels • H3= Height w/3" casters • H5= Height w/5" casters • HT= Height w/ transport or bumper guards
 WT= Width w/ transport or bumper guard • DT= Depth w/ transport or bumper guard • DP= Depth w/pass thru

SHORT FORM SPECS

Shall be Winston CVap Cook & Hold Oven model CAC507 for roasting, cooking, and holding; and utilizing Controlled Vapor Technology (U.S. Patent 5,494,690). To have means for operator to select Food Doneness Temperature (from 90 to 200° F (32 to 93° C)); Browning (0-10); and Cook Time (0 to 24 hours).

CONSTRUCTION

MATERIALS: To be commercial and institutional grade stainless steel interior and exterior to provide ease of cleaning and long service life with reasonable use and care.

RACKING OF FOOD: Adjustable racks (on 3.5" (89 mm) centers) are supplied (4 pairs). Rack supports accommodate wire racks, sheet pans, gastronorm, or steam table pans.

DOORS: Field reversible hinges to allow door lift off to facilitate cleaning. Magnetic door latch.

CASTERS: Includes 2 locking, 2 non-locking, heavy duty, non-marking.

INSULATION: Full-perimeter.

CONTROLLER: Computerized processor control with settings for doneness level, browning, cook and hold times, °F and °C button, and constant cook/hold cycle.

WATER FILL: Connect to potable water supply through saddle valve and tubing kit (supplied). Low mineral potable water is recommended, otherwise use deionizer/demineralizer to minimize corrosive damage.

VENTILATION: Allow at least 2" (51 mm) clearance on sides, particularly around ventilation holes. Install with supplied wheels or casters. Refer to owner's manual for specific installation instructions. Generally this equipment does not need to be installed under a mechanical ventilation system (vent hood). Check local health and fire codes for requirements specific to your location.

ELECTRICAL: Supplied with 84" (2134 mm) (minimum) power cord and plug.

LOAD LIMIT: 65 lbs. (29.25 kg) per rack.

WARRANTY

Limited 1 year warranty (excluding gaskets, lamps, hoses, power cords, glass panels, and evaporators). Warranty disclaimer for failure to clean. Ask for complete warranty disclosure.

SPECIFY THE FOLLOWING WHEN ORDERING:

STANDARD (NO ADDITIONAL COST):

- Voltage preference: 208V or 240V.
* Inquire about additional international voltages available.
- Hinge preference: Left or right hand hinge.
- Casters/Wheels: Choice of 1" (25 mm) wheels, 3" (76 mm) casters, or 5" (127 mm) casters.
- Controller: Silver Edition, 2 - channel control.

OPTIONAL (ADDITIONAL COST):

- Window: Window in door.
- Pass Thru: Second door on back of oven.
- Pass thru/Window: Second door on back of oven, and windows in all doors.
- Controller: Gold Edition, 6 - channel controls, HACCP recall system.
- Bumper Guard: Full-perimeter bumpers with 5" (127 mm) casters (2 locking, 2 non-locking).
- Transport: Adds bumper guard base, cord wrap, evaporator cover, and push/pull handles
- Extended Warranty: Adds parts and labor warranty coverage for one additional year.
- Added accessories or supplies.

INCLUDED ACCESSORIES (NO ADDITIONAL COST)

PS2206 Chrome wire oven racks (set of 2)

ACCESSORIES & SUPPLIES (ADDITIONAL COST)

PS2078 Stack kit w/ air space, heavy duty
 PS2090 Leg and shelf kit
 PS2192/12 ScaleKleen™ packets (12 pack)
 PS2206/4 Wire rack/tray (4 - pack)
 PS2429 External water filter for auto water fill
 PS2696 Mobile water removal system

BUY WINSTON SERVICE PARTS, ACCESSORIES, AND SUPPLIES ONLINE!

FACTORY DIRECT AT WWW.WINSTONINDUSTRIES.COM



WINSTON INDUSTRIES, LLC.
 2345 Carton Drive | Louisville, KY 40299 USA
 Phone: 800.234.5286 | 502.495.5400 | Fax: 502.495.5458 | www.winstonindustries.com
 Specifications subject to change without notice.