



**Winston
Breeder / Sifter Table
for breading, sifting, rolling,
kneading, and cutting**

BA1TA2 & BA1TA4



BA1TA2

Use & Care Manual



www.winstonind.com
800-234-5286

8525 Rev 9
rs 5-24-07

DESCRIPTION

Congratulations on your purchase of Winston's Breader/Sifter Table. You will benefit from the ability to wet and bread product, roll and cut dough, blend and sift flour or breading—and it only requires five square feet of floor space.

LOW MAINTENANCE

The Winston Breader/Sifter Table has no electromechanical parts to break down. It's virtually maintenance free. Top grade stainless steel is easy to clean up.

ACCELERATE PRODUCTION

Sift up to 25 lbs. of breading in just two minutes. The Winston Breader/Sifter Table separates dough balls while blending breading and seasonings to be reused. Lower the lid and you have additional workspace for rolling, kneading, cutting, and more.

BUILT TO LAST

Winston's Breader/Sifter Tables are designed for high volume usage. They are built to comply with all applicable standards for manufacturers. The Breader/Sifter Table is UL Sanitation approved.

We want you to be happy with your new Breader/Sifter Table. Should you have any questions or comments, please feel free to call our customer service center at 1-800-234-5286.

Thanks for your business!

Table of Contents

Description	2	Daily Care	8
Warning	3	Troubleshooting	9
Installation.....	4	ZAP Warranty	10
Nomenclature	5	Terms & Conditions	11
Operating.....	6-7		



Need to contact us? Choose the most convenient method.

Internet: www.winstonind.com

Email: contact@winstonind.com

Phone: 800-234-5286 • 502-495-5400 • Fax 502-495-5458

Mail: 2345 Carton Drive • Louisville, KY 40299 USA.

Copyright© 2007 Winston Industries, LLC. All rights reserved. CVap and Collectramatic are registered trademarks of Winston Industries, LLC. The CVap logo and Collectramatic logo are trademarks of Winston Industries, LLC. All other company and product names may be trademarks of their respective companies.

**www.winstonind.com
800-234-5286**

Read and understand this entire use and care manual before operating your breeder/sifter table.

WARNING:

Operating this appliance can be dangerous.

Read, understand, and obey the following warnings. If you do not, you could be burned, badly hurt, or killed!

- Do not stand on appliance. Do not use appliance for any purpose other than its primary functions.
- Have appliance serviced **ONLY** by a trained servicer. Do not allow personnel to operate appliance while it is being serviced.
- To prevent the hinged cover from falling when it is in the up and open position, be sure that it is locked in place with the drip pan.
- Protective gloves should be worn to prevent burns associated with handling hot baskets from fryers.
- Always perform daily cleaning procedures for this appliance. Build-up of food residues high in acid or chlorides **can cause permanent damage to the stainless steel and can contaminate foods!**

CAUTION: Prior to using appliance for the first time, perform the daily cleaning procedure listed on page 8.



www.winstonind.com
800-234-5286



SHIPPING DAMAGE

All equipment should be thoroughly examined for shipping damage before, during and after unloading. It has been carefully inspected at our factory and the **carrier has assumed responsibility for its safe arrival**. If the equipment is damaged, either apparent or concealed, **a claim must be made to the carrier**.

APPARENT LOSS OR DAMAGE

If there is an obvious loss or damage, it must be noted on the freight bill or express receipt and signed by the carrier's agent; otherwise, the carrier may refuse the claim. The carrier will supply the necessary forms.

CONCEALED LOSS OR DAMAGE

When loss or damage is not apparent until after the equipment is uncrated, a claim for concealed damage must be made. Upon discovering damage, make a request in writing to the carrier for inspection within 15 days, and retain all packing. The carrier will supply an inspection report and the required claim forms.

PHYSICAL

Model	Height incl. Legs (IN/MM)	Width (IN/MM)	Depth (IN/MM)	Weight (LBS/KG)
BA1TA2	36.7/932	58.3/481	31.3/795	131/60
BA1TA4	36.7/932	58.3/1481	31.3/795	131/60



Breader/Sifter Table Component I.D.

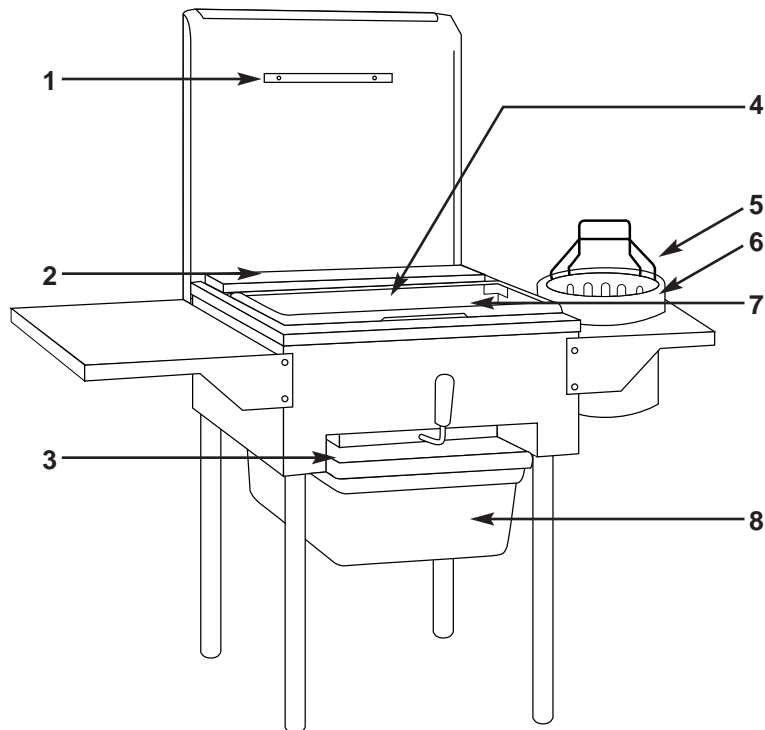

1. **Basket Hanger** - Used to place basket on for easy loading after product is breaded.
2. **Drip Pan** - Holds lid open and catches product fall-off while loading.
3. **Lug Hole Cover** - Stainless steel plate used to cover hole in top lug.
4. **Dip Bucket** - Holds water or other liquid to wet food product.
5. **Dip Basket** - Holds food product for dipping into dip bucket.
6. **Sifter Screen** - Used to recover breading by separating dough balls and breading from top lug.
7. **Lug with Hole (Top Lug)** - Product is breaded and used shortening remains are dispensed through hole for sifting.
8. **Lug without Hole (Bottom Lug)** - Used to catch clean breading after it is sifted.



www.winstonind.com
800-234-5286

OPERATING INSTRUCTIONS

Sifting

CAUTION: Prior to using appliance for the first time, perform the daily cleaning procedure listed on page 8.

1. Make sure lug hole cover is in top lug before breadings is poured into lug. Position sifter screen under lug hole. Place lug without hole in position under sifter screen.
2. Pour in breadings. Remove lug hole cover from top lug. Use lug hole cover to rake breadings through rectangular opening in bottom of lug.
3. Use handlebar on sifter screen to slide screen vigorously forward and back while sifting breadings from top to bottom lug (Figure 1).
4. When breadings is completely sifted, replace lug hole cover. Carefully pour breadings from bottom lug into top lug. Keep sufficient breadings in top lug to cover product.
5. After all breadings is sifted, remove sifter screen and discard dough balls.

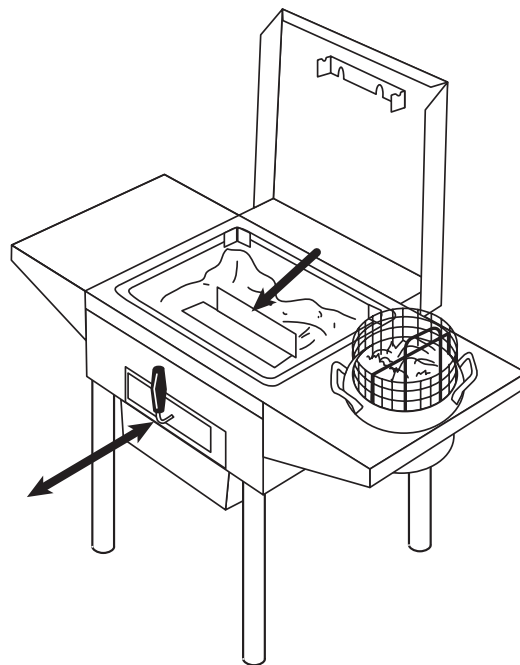

Figure 1



www.winstonind.com
800-234-5286

Breading

CAUTION: Prior to using appliance for the first time, perform the daily cleaning procedure listed on page 8.

1. Before loading basket for first cooking cycle of the day, dip clamshell basket into hot shortening; allow to drain. This prevents product from sticking to the basket. Hook open clamshell basket to basket hanger on back of cover (see Figure 2).
2. Load washed food product into dip basket; immerse into dip bucket of water (or other wetting liquid). Tilt and rest basket on edge of dip bucket to drain.
3. After excess liquid has drained off product, dump moist pieces into top breading lug. Coat all pieces thoroughly with breading.
4. Remove breaded product from lug and gently shake excess breading from product (Figure 2). Load breaded pieces onto top shelves of basket first. This allows loose breading particles to fall through basket into the lug. Place pieces close together, but do not overlap them.
5. Close loaded basket and use basket hook to lower basket into cooker. Follow your prescribed frying procedures.

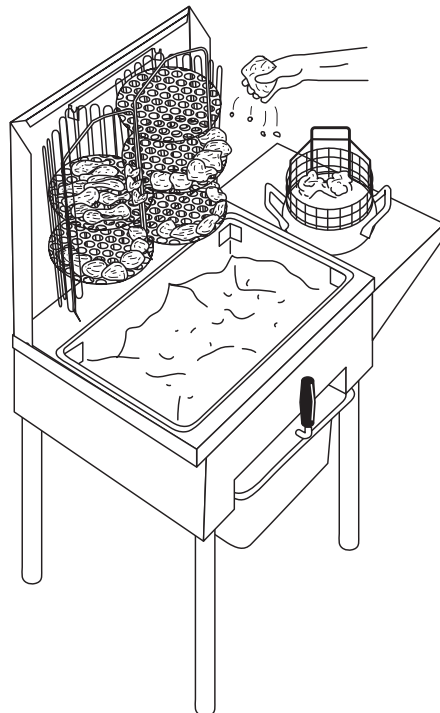

Figure 2

DAILY CLEANING

Have these items available for daily cleaning:

- Spray hose
- Food grade germicidal detergent

WARNING: Consumption of contaminated foods has the potential to produce fatal illnesses. Mandate food safety practices through DAILY CLEANING PROCEDURE.

CAUTION: Prior to using appliance for the first time, perform the daily cleaning procedure listed below.

PROCEDURE:

Clean

1. Remove all loose-fitting parts, including the sifter screen.
2. Use a scrub brush, detergent, and hot water to clean all parts.
3. Rinse all parts with hot water to remove detergent.

Sanitize

1. Dip parts or spray with 100-200ppm of chlorine sanitizing solution or food grade germicidal detergent. Allow parts to drain 5 to 10 minutes.
2. Rinse sanitizer from parts using hot water.
3. Let parts dry and reassemble breader/sifter.



www.winstonind.com
800-234-5286

SERVICE PARTS	PART NUMBER
Dip Basket	PS1292
Tray Cover Support	PS1341
Sifter Limiter	PS1705
Lug Support	PS1326
Lug Cover 18"x26"	PS1124
Lug - Bottom	PS1115
Lug - Top with Hole	PS1317
Dip Bucket	PS1581

**Service parts may be purchased directly from the factory online.
Visit www.winstonind.com**



**www.winstonind.com
800-234-5286**

**ZAP
ZERO ACCIDENTS
PROGRAM**



ZAP
Zero Accidents Program

ZAP WARRANTY AGREEMENT

This warranty agreement applies to Commercial Equipment, Equipment Service Parts, and Safety Parts (collectively, "Products") manufactured by Winston Industries, LLC ("Winston") and its corporate predecessors and is extended to any purchaser, lessee or successor purchaser ("Purchaser").

NEW EQUIPMENT

Any part of a new appliance, except gaskets, hoses, lamps, power cords, fryer baskets, glass panels, and evaporators which proves to be defective in material or workmanship within one (1) year from the date of delivery to original end-user purchaser or 18 months from the date of manufacture, whichever comes first, will be repaired or replaced (at Winston's option) free of charge.

REPLACEMENT PARTS

Any appliance replacement part except gaskets, hoses, lamps, power cords, fryer baskets, glass panels, batteries, and evaporators which proves to be defective in material or workmanship within one (1) year from the date of original installation will be repaired or replaced free of charge.

LABOR, TRAVEL, TRANSPORTATION

The warranty for new equipment covers the repair or replacement (at Winston's option) of the defective part(s), delivery of the replacement part(s), labor charges for the removal and installation of replacement part(s) for one (1) year from the start of the warranty period. This warranty includes travel time not to exceed two hours and mileage not to exceed 50 miles (100 miles round trip).

The warranty for replacement parts covers the repair or replacement (at Winston's option) of the defective part(s) and does not include any labor charges for the removal and installation of any part(s), travel, transportation or other expenses incidental to the repair or replacement of part(s).

The warranty does not cover: gaskets, hoses, lamps, power cords, fryer baskets, glass panels, evaporators, software, corrosion of stainless steel, normal maintenance, lubrication, cleaning or descaling, programming or adjusting temperatures, calibration, tightening of fasteners or plumbing connections, appliances with removed or altered identification tags, damage resulting from delivery of the appliance, customer mishandling or abuse, or no problem found.

THE USE OF POOR QUALITY WATER WILL VOID PRODUCT WARRANTIES. See Product Use and Care Manual for water quality recommendations.

PROPER INSTALLATION IS THE RESPONSIBILITY OF THE DEALER, PURCHASER, OWNER/USER, OR INSTALLING CONTRACTOR, AND IS NOT COVERED BY THIS WARRANTY.

As a condition to the application of this warranty, Purchaser will operate, clean and maintain Products in accordance with use and care instructions, warnings, manuals and any other notices and/or instructions from Winston which may be with or on Products or sent separately; will notify Winston of resale, removal or retirement of Products; will notify Winston immediately of any accident or injury arising out of use of Products and cooperate with Winston in the investigation of any such accident or injury; will maintain registration with Winston of location and serial number of Products while in Purchaser's control and use; will require all personnel operating Products to become thoroughly familiar with use and care instructions and all other notices and/or instructions before such personnel operate Products; will thoroughly train all personnel operating Products to follow all instructions contained on or in all Safety Labels and use and care instructions; will immediately affix Safety Labels and put into use the use and care instructions; will immediately use, according to instructions, Safety Parts supplied by Winston; will install Equipment Service Parts in accordance with Winston's written instructions; will utilize only Winston manufactured replacement parts and make no changes or alterations to Products, except as approved or instructed in writing by Winston; and will when requested by Winston, cooperate with Winston in the prevention of injuries from Purchaser's use of Products.

PURCHASER'S SOLE AND EXCLUSIVE REMEDY AGAINST WINSTON SHALL BE FOR THE REPAIR OR REPLACEMENT OF DEFECTIVE PARTS AS PROVIDED HEREIN. THE TOTAL LIABILITY OF WINSTON WITH RESPECT TO ITS PRODUCTS, WHETHER UNDER WARRANTY OR OTHERWISE, SHALL NOT EXCEED THE PURCHASE PRICE OF THE PRODUCTS AND THE LABOR AND TRAVEL TO REPLACE THE PRODUCTS OR ANY PART THEREOF. WINSTON SHALL NOT BE LIABLE TO THE PURCHASER OR OTHERS FOR ANY DIRECT, INDIRECT, SPECIAL, INCIDENTAL OR CONSEQUENTIAL DAMAGES OR LOSS OF PROFITS RESULTING FROM ANY CAUSE WHATSOEVER, INCLUDING BUT NOT LIMITED TO, DEFECTIVE WORKMANSHIP, MATERIALS OR ANY ERROR OR OMISSION OF WINSTON.

WINSTON EXPRESSLY DISCLAIMS ALL OTHER WARRANTIES, EITHER EXPRESS OR IMPLIED, INCLUDING ANY IMPLIED WARRANTY OF FITNESS FOR A PARTICULAR PURPOSE AND ANY IMPLIED WARRANTY OF MERCHANTABILITY.

For warranty inquiries and customer specific warranties, call Winston Customer Service at 1-800-234-5286 or 502-495-5400.

Prices subject to change without notice.
F.O.B. Louisville, KY, USA

(800) 234-5286 or (502) 495-5400 Fax (502) 495-5458
www.winstonind.com
All sales subject to Company's Terms and Conditions

Winston Products Company
2345 Carton Drive
Louisville, KY 40299



TERMS AND CONDITIONS OF SALE

In consideration of the mutual benefits hereby to be derived, Winston Industries, LLC ("Winston") and any purchaser, lessee or successive purchaser ("Purchaser"), of Winston Commercial Equipment, Equipment Service Parts, and Safety Parts (collectively "Products") agree that:

1. Terms of sale for Products are net 25 (payment must be received within 25 days from invoice date). Prices are subject to change without notice. Purchaser agrees to pay all costs of collection of past due accounts, including reasonable attorney's fees. All claims must be made within five (5) days of receipt of goods or claim will not be allowed. All goods are shipped at Purchaser's risk. Confirmed orders may not be cancelled or delayed without written permission from Winston. Cancelled or delayed orders may be subject to a 20% inventory adjustment/warehousing fee. Delayed orders will be invoiced on the confirmed ship date. Products may not be returned without written permission from Winston as described in paragraph #6 below. Orders placed prior to a price increase, which are due to ship after the increase, may be charged at the new price.
2. An order will not be effective until accepted by an authorized representative at Winston's home office. Unless otherwise specified in writing (a) delivery will be made F.O.B. Louisville, Kentucky and risk of loss or damage shall pass to Purchaser upon delivery to the carrier, and (b) the method or agency of transportation and routing will be selected by Winston. Winston reserves the right to ship freight collect.
3. Winston shall not be liable for any delay in performance due to fire, explosion, casualty, strike or other labor difficulties, shortage of utility facility, delay to transportation, breakdown or accident, compliance with other action to carry out the intent or purpose of any law or regulation, or any cause, whether similar or dissimilar, beyond Winston's reasonable control and Winston shall have such additional time for performance as may be reasonably necessary under the circumstances and the right to apportion its production among its customers in such a manner as it may deem equitable.
4. Purchaser agrees to indemnify and hold Winston harmless from any loss, cost or expense, including cost of defense, and reasonable attorney's fees, incurred by Winston, arising from or related to (1) Purchaser's use or sale of Products, including, but not limited to, Purchaser's failure to warn Purchaser's workers and others of hazards involving the Products; Purchaser's failure to provide copy of Terms and Conditions at time of sale of Products to others; Purchaser's failure to instruct Purchaser's workers and others in how to safely use the Products in compliance with the Use and Care Manual; and Purchaser's failure to provide safe working conditions and proper safety clothing and gear with respect to the Products, and (2) non-compliance with these Terms and Conditions, or both.
5. Purchaser shall pay, in addition to the price hereunder, as a separate item, any taxes which Winston may be required to pay or collect under existing or future laws with respect to the sale, delivery, transportation, or use of any Product sold hereunder including all taxes, however designated, upon or measured by amounts paid to Winston by Purchaser hereunder, except net income tax.
6. Products may not be returned by Purchaser except by prior written agreement with Winston. Returns without prior authorization, as indicated by an RA number applied to the returned packaging, will be refused. All returned Products are subject to inspection by Winston and a 20% restocking charge (\$30 minimum), which may be reduced if replacement Product is ordered, plus any other costs necessary to restore the Products to new condition. The Products must be returned to the Winston factory freight prepaid, in new condition, and in the original packaging. Winston reserves the sole right to determine the amount of credit to be issued on any Products returned for credit. Only standard, currently manufactured Winston Products may be considered for return and credit. No returns will be accepted on modified or special order Products (built to a Purchaser's specifications), used Products, or on Products older than 90 days from the original date of shipment.
7. Acceptance is expressly limited to the Terms and Conditions set forth herein and any additional or different terms proposed by Purchaser are rejected unless expressly assented to in writing. In the event during the course of dealing, Winston signs or otherwise accepts any documents or forms submitted by Purchaser containing any Terms or Conditions contrary to or in addition to those of Winston set forth herein, such documents and forms shall be deemed to have been used for the mere convenience of Purchaser in the conduct of its internal business affairs and not for the purpose of varying the Terms and Conditions of this order. This order including these Terms and Conditions shall constitute entirely the Terms and Conditions between the parties with respect to the transaction covered hereby and to all subsequent transactions for Products obtained from Winston, and no waiver, alteration or modification shall be binding on Winston unless in writing and signed by an authorized officer of Winston at its home office.
8. Purchaser's sole warranty is the Zero Accident Program (ZAP) Warranty Agreement on products manufactured by Winston in effect at the time of the sale. OTHER THAN THE ZAP WARRANTY AGREEMENT, WINSTON MAKES NO WARRANTY OF ANY KIND WHATSOEVER, EXPRESS OR IMPLIED, CONCERNING THE PRODUCTS. WINSTON EXPRESSLY EXCLUDES ALL IMPLIED WARRANTIES OF MERCHANTABILITY OR FITNESS FOR A PARTICULAR PURPOSE. THE TOTAL LIABILITY OF WINSTON WITH RESPECT TO ANY PRODUCT SHALL IN NO EVENT EXCEED THE PURCHASE PRICE THEREOF, AND LABOR TO REPLACE. WINSTON SHALL IN NO EVENT BE LIABLE TO PURCHASER OR OTHERS FOR ANY DIRECT, INDIRECT, SPECIAL, INCIDENTAL, OR CONSEQUENTIAL DAMAGES OR LOSS OF PROFITS RESULTING FROM ANY CAUSE WHATSOEVER, INCLUDING, BUT NOT LIMITED TO, DEFECTIVE WORKMANSHIP, MATERIALS OR ANY ERROR OR OMISSION OF WINSTON.
9. Winston shall not be liable for claims of patent infringement against Purchaser or Purchaser's loss of the right to use the Product.
10. ARBITRATION: Any controversy or claim arising out of or relating to this Order, or the breach thereof, shall be settled by binding arbitration in accordance with the Commercial Arbitration Rules of the American Arbitration Association, except that any arbitration hearing shall be held in Louisville, Kentucky. Judgment upon the award rendered by the arbitrator(s) may be entered in any court having jurisdiction thereof. Any application for review of an arbitration award shall be allowed only to the extent required by Kentucky law and shall be brought in an appropriate court in the Thirteenth Judicial Circuit or District of Kentucky, or in the United States District Court for the Western District of Kentucky.
11. GOVERNING LAW: This Order and the rights, duties and legal relations of the parties, and any arbitration are governed by and construed under Kentucky laws.
12. The products sold hereunder are produced in compliance with the Fair Labor Standards Act.

Prices subject to change without notice.
F.O.B. Louisville, KY, USA

(800) 234-5286 or (502) 495-5400 Fax (502) 495-5458
www.winstonind.com
All sales subject to Company's Terms and Conditions

Winston Products Company
2345 Carton Drive
Louisville, KY 40299