

CVap®

MGB007

CVap® Display Cabinet

Counter top model, fanless

Electronic differential control

General Specifications

- CVap® display cabinets are designed for high quality holding of a wide variety of menu items for extended times.
- Exclusive patented Controlled Vapor Technology (U.S. patent # 5,494,690) establishes that the water vapor content in the cabinet is the same as that of the food. This unique process controls moisture evaporation and saturation, so crisp foods stay crisp, moist foods stay moist.
- Electronic differential controls are easy to understand and reliable. Never require field calibration. FOOD TEMP KEYS allow precise control of food temperature from 90° to 180°F (32° to 82°C). FOOD TEXTURE KEYS maintain just-cooked texture. Set near FOOD TEMP for moist foods, or set higher for crisp foods.
- Built to last with quality craftsmanship, high grade stainless steel construction, and tempered double-pane glass.
- Four perforated stainless steel trays allow you to merchandise any hot food for maximum impact.
- Features full perimeter door gaskets, magnetic door latches, lift-off doors, adjustable trays, and digital readout for water temperature.
- CVap equipment complies with all domestic, and most international requirements, such as UL, C-UL, UL Sanitation, CE, MEA, and others.



MGB007-RL
with optional
rotating racks
and lighted sign

MGB007 with
standard
shelves

Functions: Hold & Serve

Capacity:

MGB007 4 Steam Table Pans
2.5" (64mm) deep
8 Half Steam Table Pans

MGB007-RL 4 18" (457mm)-diameter
round pans



Winston Industries, LLC.



Winston Products International, Ltd.



MGB007 CVap® Display Cabinet Counter top model, fanless Electronic differential control

**Buy Winston Service
Parts Online!**
Factory direct at
www.winstonind.com

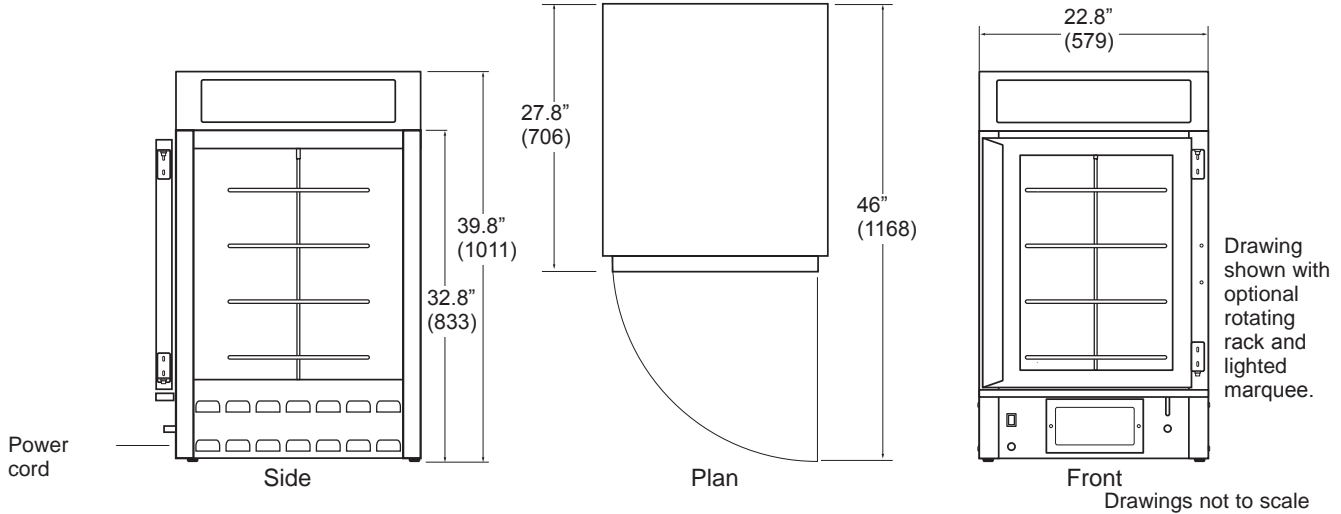

Capacity	Size in (mm)	Volts	Hertz	PH	Amps	Watts	Circuit Amps	Ship Wt lb (kg)	Ship Cube ft (M)	Class	NEMA Plug Type
MGB007 4 STP	H =32.8" (833) HR =39.8" (1011)	US/Canada									
8 Half STP MGB007-RL 4 18" round pans	W =22.8" (579) D =27.8" (706)										5-15P US / Canada
	MGB007	120	60	1	11.7	1400	US/CAN 15	133 (61)	18.3 (.52)	100	5-20P Canada
	MGB007-RL	120	60	1	12.1	1453	US15/CAN20	call factory	call factory		

H=Height of standard cabinet • HR=Height w/optional rotating shelves and lighted sign

Short Form Specs

Shall be Winston CVap display cabinet, model MGB007 with electronic differential control to provide precise food temperature from 90° to 180°F (32° to 82°C) and maintain food texture. Utilizes Controlled Vapor Technology (patent #5,494,690) as a method and apparatus for holding hot foods, consisting of an air heater and water heater to establish ideal water vapor content that is in relation with the moistness characteristics for the food.

Construction

Materials: To be commercial and institutional grade stainless steel to provide ease of cleaning and long service life with reasonable use and care. Utilizes double-paned tempered glass for safety and efficiency.

Racks: Four perforated shelves. Optional rotating rack holds four pizza pans. Removable for easy cleaning.

Doors: Field reversible hinges to allow door lift off to facilitate cleaning. Magnetic door latch.

Controller: Electronic differential control with keys labeled Food Temp and Food Texture.

Water Fill: Operated manually. Low mineral potable water is recommended, otherwise use deionizer/demineralizer to minimize corrosive damage. Visible and audible Low Water indication is standard.

Ventilation: Allow 2" (51mm) ventilation clearance on sides, back, and top of appliance. Install with supplied legs or casters. Refer to use & care manual for specific installation instructions. Generally this appliance does not need to be installed under a mechanical ventilation system (vent hood). Check local health and fire codes for requirements specific to your location.

Electrical: Supplied with 84" (2134mm) minimum power cord and plug.

Warranty

Limited 1 year warranty (excluding gaskets, lamps, hoses, power cords, glass panels, and evaporators). Warranty disclaimer for failure to clean. Ask for complete warranty disclosure.

Model

MGB007
MGB007-RL

Description

CVap hold/display, removable shelf racks
CVap hold/display, rotating round racks, lighted marquee

- Customer should specify the following when ordering:**
- Hinge preference (left or right) (no additional cost).**
 - Any added options or optional items.**

Options

Removable racks	Racks containing four shelves (base model)
Hinging	Specify left hand or right hand hinge
Lighted Sign	Lighted marquee on top of cabinet
Pass Thru	Second door on back of cabinet
Lighted Sign, Pass Thru	Lighted marquee and second door added
Rotating Racks, Lighted Sign, Pass Thru	Rotating round racks, motor housed within lighted marquee, second door added
Extended Warranty	Adds parts and labor warranty coverage for one additional year

Note: Graphic materials for lighted sign should be obtained from your local graphics vendor.

Optional Items

PS2192/12 ScaleKleen™ packets (12 pack)
Options and optional items available for an additional cost.

Winston Industries, LLC.



Winston Products International, Ltd.