

CVap®

CAT529-BD CVap Therm & Hold Cabinet with Basket Dolly Full size model with fan

8000 Series, 8 Channel Electronic Control

General Specifications

- Exclusive patented Controlled Vapor Technology (U.S. patent # 5,494,690) establishes that the water vapor content in the cabinet is the same as that of the food. This unique process gently reheats food to the highest yield and desired doneness temperatures every time.
- Easy-to-use controls. Simply select one of eight factory preprogrammed retherm and hold cycles. Each channel can be adjusted to fit your exact time and temperature need. The cabinet automatically holds food precisely at FDA-recommended temperatures and times. The control never needs calibration.
- Built to last with quality craftsmanship, high grade corrosive-resistant stainless steel construction and full perimeter high-temp mineral fiber insulation.
- Accommodates mobile basket dolly (not included) for easy transporting and handling of meals from packaging to freezer, to refrigeration, to retherm location (satellite site) and serving line.
- Automatic pre-programmed hold cycle.
- CVap equipment complies with all domestic, and most international requirements, such as UL, C-UL, UL Sanitation, CE, MEA, and others.



CAT529-BD

Functions: Retherm and hold

Capacity: See separate spec sheets for capacity on different dolly configurations.

Menu Application Precooked, prepackaged meals or individual food items, à la carte foods such as vegetables, sandwiches, ground and whole proteins, casseroles, combination dishes, soups, sauces, and some bake-able fry foods in wire baskets.

Segment Application Schools and institutions

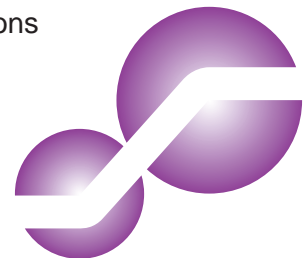

Winston Industries, LLC.  Winston Products International, Ltd.



CAT529-BD
CVap Therm & Hold Cabinet with Basket Dolly
 Full size model with fan
 8000 Series, 8 Channel Electronic Control

Buy Winston Service Parts
 Online!
 Factory direct at
www.winstonind.com

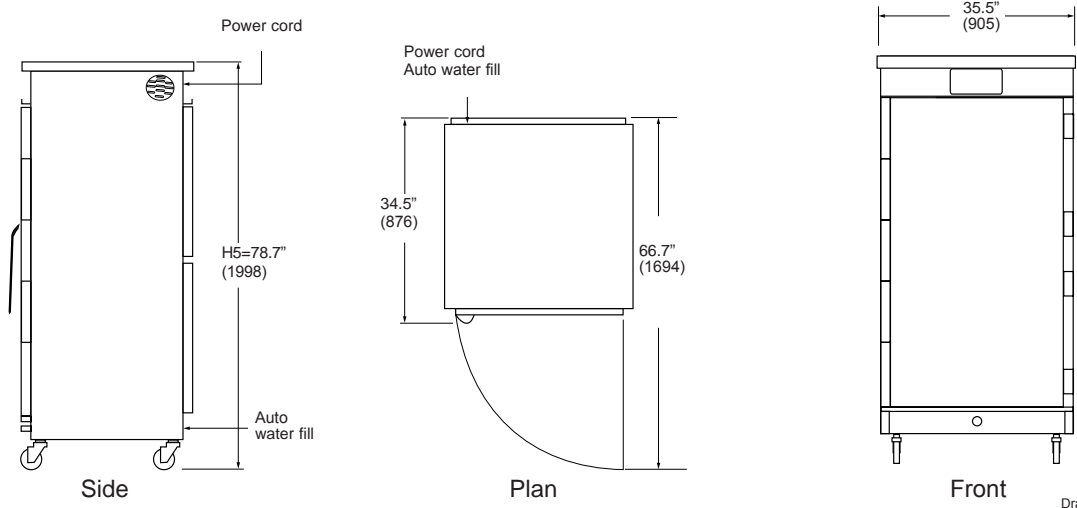

Drawings not to scale

Capacity	Size in (mm)	Volts	Hertz	PH	Amps	Watts	Circuit Amps	Ship Wt lb (kg)	Ship Cube ft (M)	Class	NEMA Plug Type
See separate dolly spec sheets.	H =78.7" (1998) W =35.5" (902) D =34.5" (876)	US/Canada									
		208	60	3	33.7	11215	50	560 (252)	70.4 (2.0)	100	
		240	60	3	29.2	11215					
		International									
Not available for the international market at this time.											

Short Form Specs

Shall be Winston CVap therm & hold cabinet with basket dolly, Model CAT529BD, for reheating and holding precooked foods. Utilizes Controlled Vapor Technology (U.S. Patent #5,495,690) as a method and apparatus for reheating and holding hot foods, consisting of an air heater and water heater to establish ideal water vapor content that is in relation with the moistness characteristics for the food.

Construction

Materials: To be commercial and institutional grade stainless steel to provide ease of cleaning and long service life with reasonable use and care.

Basket Dolly: Heavy-duty stainless steel construction with four swivel heavy-duty casters. Available with wide basket, narrow basket, or narrow refrigeration configurations.

Doors: Magnetic door latch.

Casters: 5" (127mm), includes two locking, heavy duty, non-marking.

Insulation: Full-perimeter high-temp mineral fiber.

Controller: Computerized processor control with eight pre-programmed retherm cycles which can be operator-

adjusted to precise temperature, food texture, and time. Will automatically hold if required.

Water fill: Optional use automatic water fill system includes a saddle valve and 1/4" (6mm) flexible tubing kit. Connection located at lower left back of cabinet. Low mineral potable water is recommended, otherwise use deionizer/demineralizer to minimize corrosive damage.

Ventilation: Allow 2" (51mm) clearance on sides, particularly around ventilation holes. Install with supplied legs or casters. Refer to use & care manual for specific installation instructions. Generally this appliance does not need to be installed under a mechanical ventilation system (vent hood). Check local health and fire codes for requirements specific to your location.

Electrical: Supplied with 84" (2134mm) (minimum) power cord, and plug.

Warranty

Limited 1 year warranty (excluding gaskets, lamps, hoses, power cords, glass panels, and evaporators). Warranty disclaimer for failure to clean. Ask for complete warranty disclosure.

Model
CAT529-BD

Description
CVap therm & hold, fan, basket dolly w/cart, auto fill

- Customer should specify the following when ordering:**
- Electrical preference (208V or 240V) (no additional cost).**
 - Dolly type to be utilized (Wide Basket, Narrow Basket, or Narrow Refrigeration).**
 - Hinge preference (left or right) (no additional cost).**
 - Any added options or optional items.**

Also available without basket dolly.

Options

- Hinging** Specify left hand or right hand hinge.
- Silver Edition** Silver Edition controls, 8-channel control (standard)
- Bumper Guard** Full-perimeter bumpers with 5" (127mm) casters (2 locking).
- Dolly Cart** One dolly cart per unit is included. Choose between wide basket, narrow basket, and narrow refrigeration configurations.
- Transport** Adds bumper guard base, cord wrap, and evaporator cover.
- Extended Warranty** Adds parts and labor warranty coverage for one additional year.

Optional Items

- 6411AD09 Basket dolly - Wide
- 6411AD10 Basket dolly - Narrow
- 6411AD11 Basket dolly - Narrow Refrigeration
- PS2192/12 ScaleKleen- packets (12 pack)
- PS2429 External water filter for auto water fill
- PS2696 Mobile water removal dolly

Options and optional items available for an additional cost. See separate spec sheets for capacity information on basket dollies.

Winston Industries, LLC.



Winston Products International, Ltd.