

# CVap®

## HBB5D2 CVap® Hold & Serve Drawer With fan

Electronic differential controls

### General Specifications

- CVap® hold & serve drawers are designed for high quality holding and serving of a wide variety of menu items for extended times.
- Patented Controlled Vapor Technology (U.S. patent #5,494,690) establishes that the water vapor content in the cabinet is the same as that of the food. This unique process controls moisture evaporation and saturation, so crisp foods stay crisp, moist foods stay moist.
- Two electronic differential control key sets are easy to understand and reliable. These controls never need field calibration.  
FOOD TEMP KEYS allow control of food temperature from 90°F (32°C) to 180°F (82°C).  
FOOD TEXTURE KEYS maintain just-cooked texture. Set near FOOD TEMP for moist foods, or set higher for crisp foods. 250°F (121°C) maximum cabinet temperature.
- Built to last with quality craftsmanship, high grade stainless steel construction and full perimeter insulation.
- Features radial fan for improved food quality with frequent openings, full perimeter drawer gaskets, and digital readout for water temperature.
- CVap equipment complies with all domestic, and most international requirements, such as UL, C-UL, UL Sanitation, CE, MEA, and others.



HBB5D2

**Functions:** Hold & Serve

**Capacity:** 2 Steam Table Pan  
12" x 20" x 6"  
(305mm x 508mm x 152mm)  
4 Half Steam Table Pans  
6 Third Steam Table Pans  
2x1/1 Gastronorm Pans

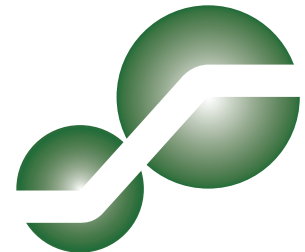

Winston Industries, LLC.  Winston Products International, Ltd.



# HBB5D2 CVap® Hold & Serve Drawer With fan

Electronic differential controls

Buy Winston Service Parts  
Online!  
Factory direct at  
[www.winstonind.com](http://www.winstonind.com)

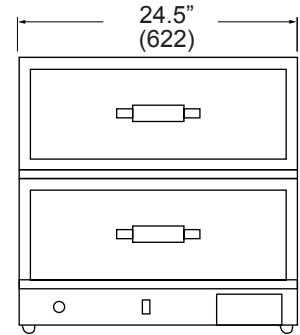
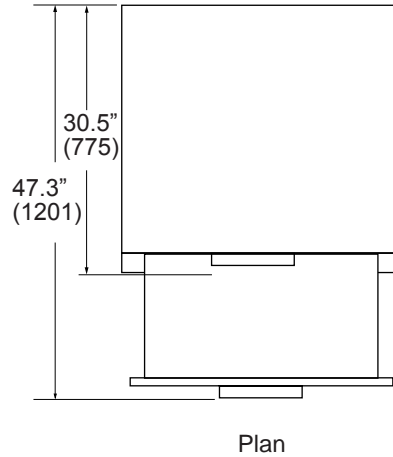
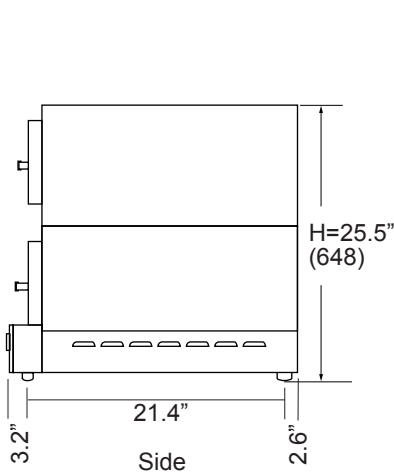

Front  
Drawings not to scale

Capacity	Size in (mm)	Volts	Hertz	PH	Amps	Watts	Circuit Amps	Ship Wt lb (kg)	Ship Cube ft (M)	Class	NEMA Plug Type
2 STP 4 half STP 6 third STP 2 x1/1 GP  Accepts up to 6" (152mm) deep pans.	H= 25.5" (648) W=24.5" (622) D= 30.5" (775)	<b>US/Canada</b>									
		120	60	1	13.1	1572	US 15 CAN 20	115 (52)	11.7 (0.33)	100	 5-15P United States   5-20P Canada
<b>International</b>											
		230*	50	1	6.8	1572	N/A	w/skid 140(64)	w/skid call factory	N/A	

STP=Steam Table Pan (12"x20"x6") • GP=Gastronorm Pan

### Short Form Specs

Shall be Winston CVap hold & serve drawer, model HBB5D2 with electronic differential controls. Utilizes Controlled Vapor Technology (U.S. Patent #5,494,690) as a method and apparatus for holding hot foods, consisting of an air heater and water heater to establish ideal water vapor content that is in relation with the moistness characteristics for the food.

### Construction

**Materials:** Interior to be stainless steel to provide ease of cleaning and long service life with reasonable use and care.

**Drawers:** To accept 2 full steam table pan (6" (152mm) deep), 4 half steam table pans, 6 third steam table pans, or 2 1x1 gastronorm pans. Easy to remove and replace.

**Insulation:** Full-perimeter.

**Controller:** Electronic differential control allows precise control of food temperature and food texture.

**Evaporator:** Holds approximately 0.8 gallons (3L) of water.

**Water fill:** Operated manually. Low mineral potable water is recommended, otherwise use deionizer/demineralizer to minimize corrosive damage.

**Ventilation:** Allow space around appliance for good air circulation. Refer to use & care manual for specific installation instructions. Generally this appliance does not need to be installed under a mechanical ventilation system (vent hood). Check local health and fire codes for requirements specific to your location.

**Electrical:** Supplied with 7' (213cm) (minimum) power cord and plug.

**Load limit:** 20 lbs. (9.07 kg) per drawer.

### Warranty

Limited 1 year warranty (excluding gaskets, lamps, hoses, power cords, glass panels, and evaporators). Warranty disclaimer for failure to clean. Ask for complete warranty disclosure.

### Model

HBB5D2

### Description

CVap hold/serve, fan, 2 drawer, wide

Customer should specify the following when ordering:

1. Leg or foot preference (no additional cost).
2. Any added options or accessories.

\* *Inquire about additional international voltages available.*

### Options

- |                   |   |
|-------------------|---|
| Leg or foot       | Choice of 1/2" (13mm) feet or 4" (102mm) legs                   |
| Extended Warranty | Adds parts and labor warranty coverage for one additional year. |

### Optional Items

- |           |                                  |
|-----------|----------------------------------|
| PS2192/12 | ScaleKleen® packets (12 pack)    |
| PS2259    | Water fill trough                |
| PS2212    | Perforated tray (for HBB models) |

*Options and accessories available for an additional cost.*

Winston Industries, LLC. Winston Products International, Ltd.